

Mechanical Engineering

Vibration Screens

Type 500 K,
Type 1000 K,
Type 1000 SCH

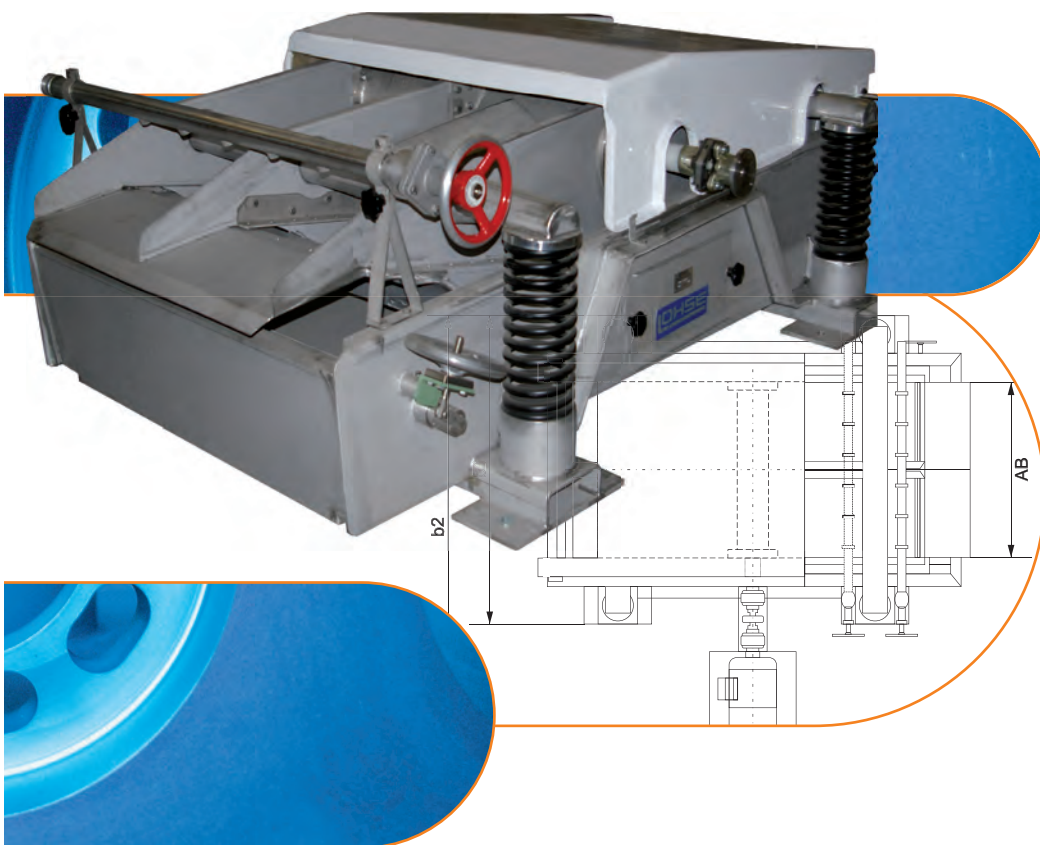

Maschinenbau Lohse GmbH
Unteres Paradies 63 · 89522 Heidenheim
phone +49 7321 755-79
sales@lohse-gmbh.de
www.lohse-gmbh.de

Application

Due to the optional use of perforated and slotted sheets vibration screens are suitable for any grading tasks encountered in the paper industry, both in the low and high-density range.

Construction

- stainless steel or steel grading tub with protective rubber coating
- screen basket supported by sprung stainless steel cross bars within the tub, screen basket provided with a baffle frame
- waterproof enclosed unbalance support including permanently set unbalance mass
- easily replaceable perforated or slotted sheet screens
- type B3 drive motor including an articulated shaft, adjustable baffle flap for back-up of accepts
- spray pipe for fibrous return water
- plastic folding canopy

Operation

The vibration screens is suitable for universal use. Due to its design and allowing the use of perforated or slotted sheets for grading, the grader is easily adjusted to any type of fibrous material.

Due to fast removal of coarse screenings based on a relatively high vibration frequency of the screening basket and the chosen vibration amplitude being higher than the maximum fibre length encountered, smooth operation without any spinning or blocking will be feasible. Improved removal of coarse screenings by use of a baffle flap below the screening sheet.

Depending on the graded size, the pulp will pass through one or two inlets towards the screening basket. Screened coarse screenings are carried out through the screening basket projecting from of the grader. In order to support the grading effect, accepts are dammed by an adjustable overflow flap within the tub. Overflowing accepts will leave the grader by an aperture in the tub bottom.

A spray pipe is used for back-washing of any good fibres adhering to coarse screenings. The vibration screens is covered by a plastic canopy. This canopy and the screening basket may be easily folded up and/or removed for cleaning.

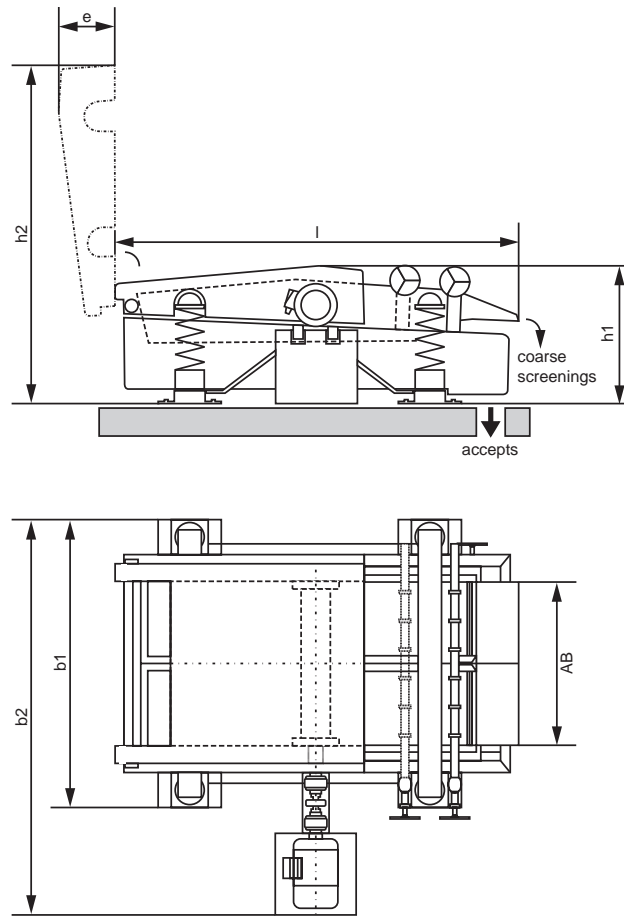

Technical data

screening size		500	1000
low-density pulp screening			
pulp density	[%]	2	2
throughput	[t/24h]	3 – 11	10 – 33
high-density pulp screening			
pulp density	[%]	2 – 4,5	2 – 4,5
throughput	[t/24h]	5 – 23	15 – 65
AB (working width)	[mm]	~ 500	~ 1000
b1	[mm]	1040	1800
b2	[mm]	~ 1510	~ 2450
e	[mm]	~ 290	~ 405
h1	[mm]	~ 710	~ 910
h2	[mm]	~ 1480	~ 2530
l	[mm]	~ 1760	~ 2510
engine power	[kW]	1.1	1.1
empty weight	[kg]	420	1300

Application

This robust vibration screen with a large screening area is used in wood grinding plants as a means to catch tailings and thus to separate the splinters and tailings from ground wood.

Construction

- stainless steel grading tub
- screen basket supported by sprung stainless steel cross bars within the tub
- waterproof enclosed unbalance support including permanently set unbalance mass
- easily replaceable perforated sheet screens
- type B3 drive motor including an articulated shaft, adjustable baffle flap for back-up of accepts
- spray pipe for fibrous return water

Operation

The vibration screen is suitable for universal use. Due to its design and allowing the use of perforated sheets for grading, the grader is easily adjusted to any type of fibrous material.

Due to fast removal of coarse screenings based on a relatively high vibration frequency of the screening basket and the chosen vibration amplitude being higher than the maximum fibre length encountered, smooth operation without any spinning or blocking will be feasible. Improved removal of coarse screenings by use of a baffle flap below the screening sheet.

Depending on the graded size, the pulp will pass through one or two inlets towards the screening basket. Screened coarse screenings are carried out through the screening basket projecting from of the grader. In order to support the grading effect, accepts are dammed by an adjustable overflow flap within the tub. Overflowing accepts will leave the grader by an aperture in the tub bottom.

A spray pipe is used for back-washing of any good fibres adhering to coarse screenings. The screening basket may be easily folded up and/or removed for cleaning.

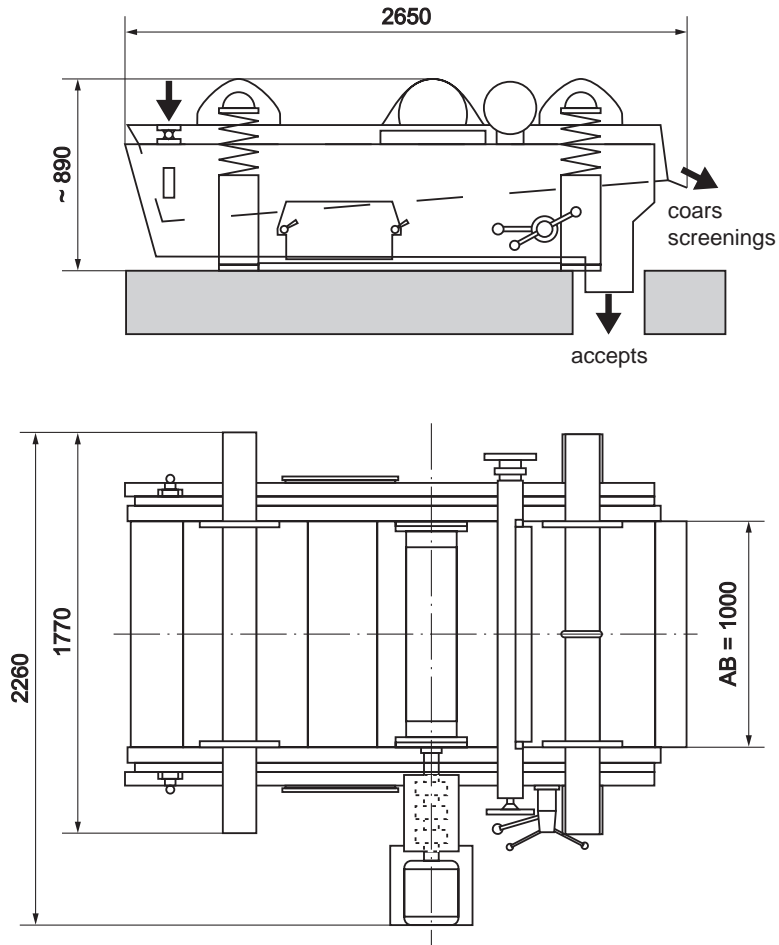

Technical data

throughput (depending on type and density of pulp and on perforation of sheet screen)	[t/24h]	60 ... 80
stock consistency	[%]	2
perforation of sheet screen	Ø [mm]	4 ... 6
usage of splash water	[l/min]	~ 150
pressure of splash water min.	[bar]	2
speed	[1/min]	1500
engine power	[kW]	3
empty weight	[kg]	1300