

Mechanical Engineering

# Axial Fans

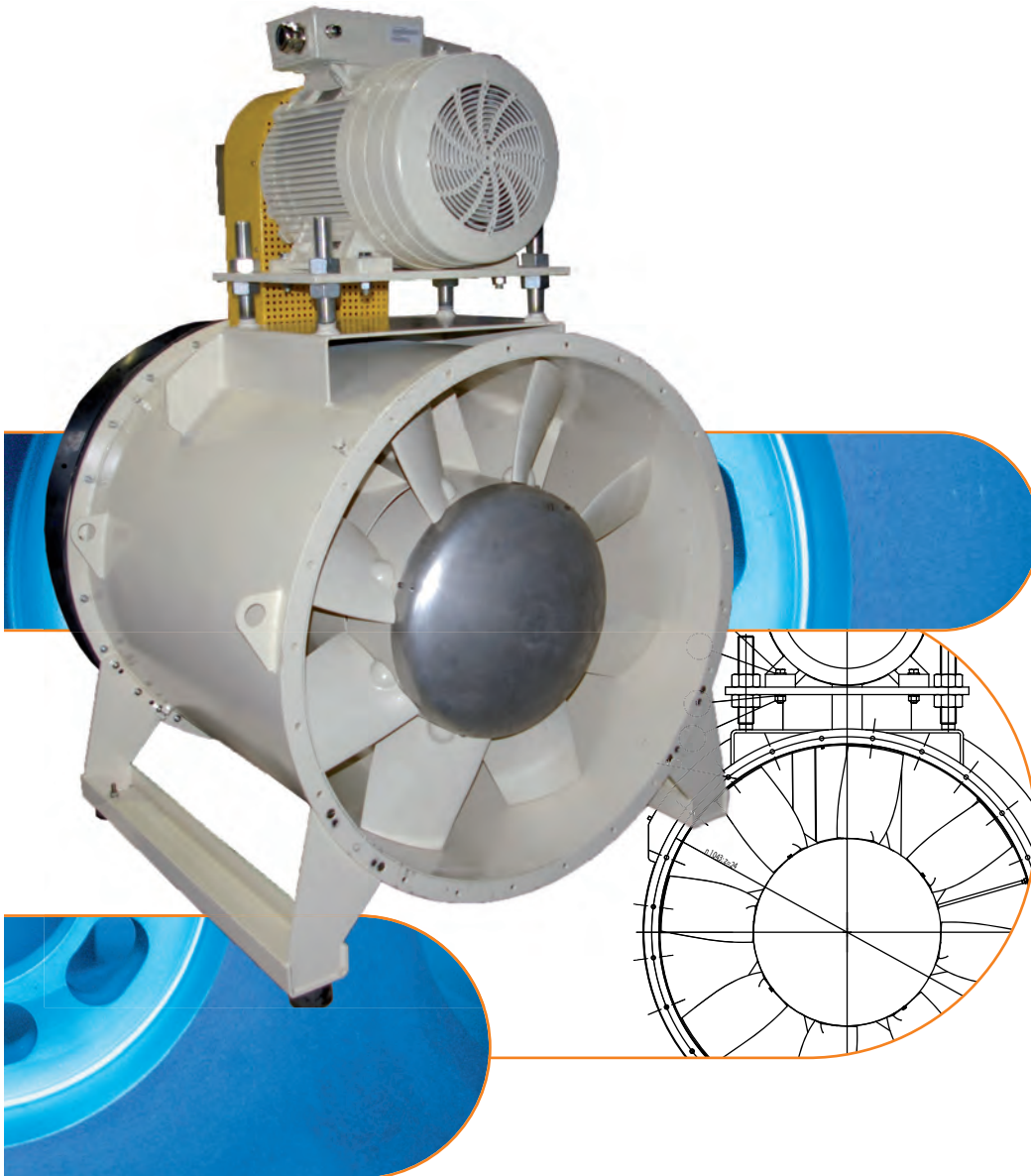

Maschinenbau Lohse GmbH  
Unteres Paradies 63 · 89522 Heidenheim  
phone +49 7321 755-79  
sales@lohse-gmbh.de  
www.lohse-gmbh.de

The fans will have impeller blades which can be adjusted, stepless during stand still.

The axial fan program M 80 consists as a standard of 2 x 15 different sizes and arrangements, direct driven or belt driven.

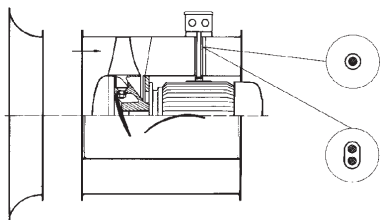

A-drive (direct drive)

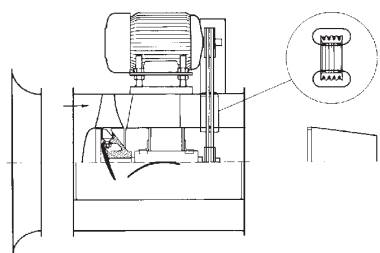

C-drive (belt drive)

Direct drive	Belt drive
400.250.6.A/M80	400.250.6.C/M80
500.315.6.A/M80	500.315.6.C/M80
630.315.6.A/M80	630.315.6.C/M80
630.400.6.A/M80	630.400.6.C/M80
800.500.8.A/M80	800.500.8.C/M80
800.315.6.A/M80	800.315.6.C/M80
800.250.6.A/M80	800.250.6.C/M80
1000.630.8.A/M80	1000.630.8.C/M80
1000.500.8.A/M80	1000.500.8.C/M80
1000.315.6.A/M80	1000.315.6.C/M80
1250.630.8.A/M80	1250.630.8.C/M80
1250.500.8.A/M80	1250.500.8.C/M80
1600.630.8.A/M80	1600.630.8.C/M80
1600.500.8.A/M80	1600.500.8.C/M80
2000.630.8.A/M80	2000.630.8.C/M80

Through direct drive the fan speed can be varied in the following steps:  
750 – 1000 – 1500 – 3000 rpm at 50 Hz / 900 – 1200 – 1800 – 3600 rpm at 60 Hz

Through belt drive a wider range of speed can be obtained. These variations give a wide working area for the axial fan M 80. It is possible to obtain capacities from 360000 m<sup>3</sup>/h using fan 2000.630.8A/M 80 down to 1800 m<sup>3</sup>/h with the fan 400.250.6A/M 80. It is further possible to obtain pressure up to 3600 Pa with the fan 800.500.8C/M 80.

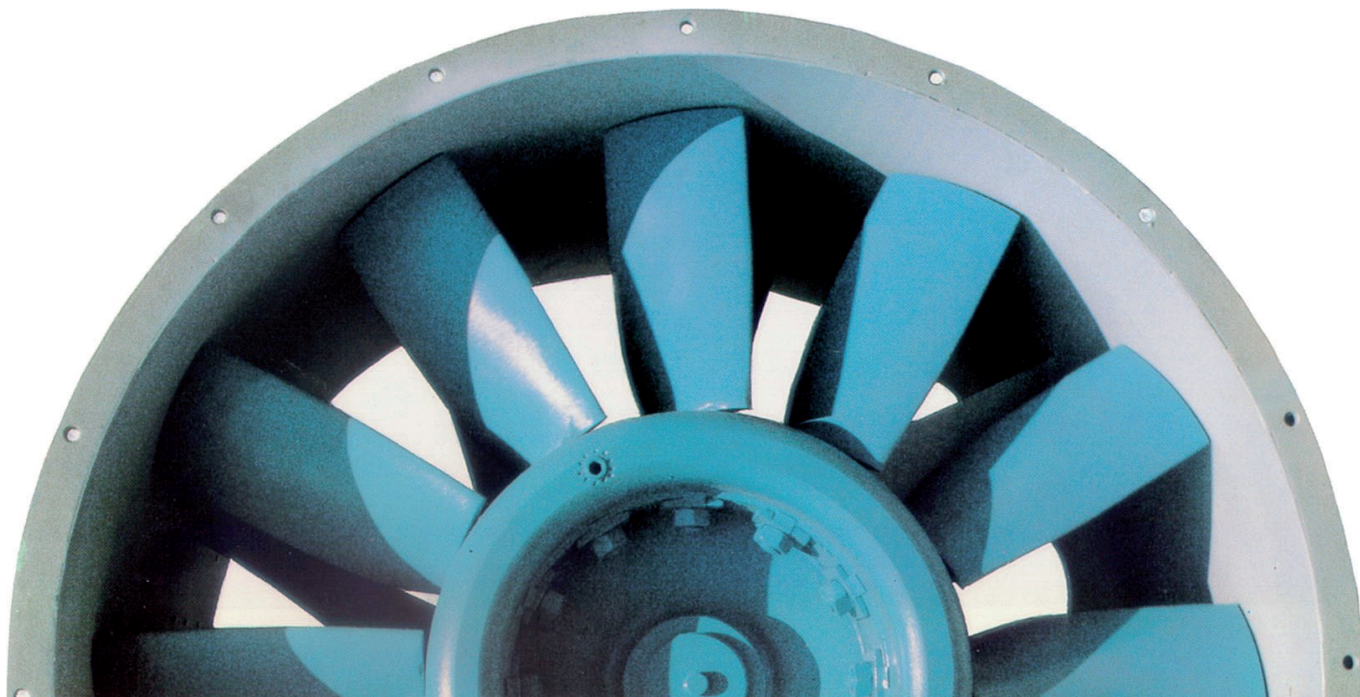

## High efficiency axial fan

Through work done in Voiths research laboratory, it has been possible to optimize the profile of the wings, which gives a very high efficiency. In the medium pressure area efficiencies up to 90%, and in high pressure areas 85% can be obtained. Taking into consideration today's high energy prices, these are very important factors when the pay back is considered.

The technical design when manufacturing the fan housing and impellers gives the best results with regard to leakage losses between impeller and inlet cone. In that way it is possible to keep a high efficiency.

The complete unit with central tube, cables – and belt covers have an aerodynamic optimum design.

With belt driven fans, it is possible as accessories instead of the cover which is located on the outlet of the central tube, to mount a rear piece which will be formed as an inside diffuser. In that way it is possible to regain part of the static pressure.

A special inlet cone can be mounted on fans with open inlet, and the inlet loss will then be reduced. A special designed cover over the fan wheel hub ensures a best possible inlet air flow.

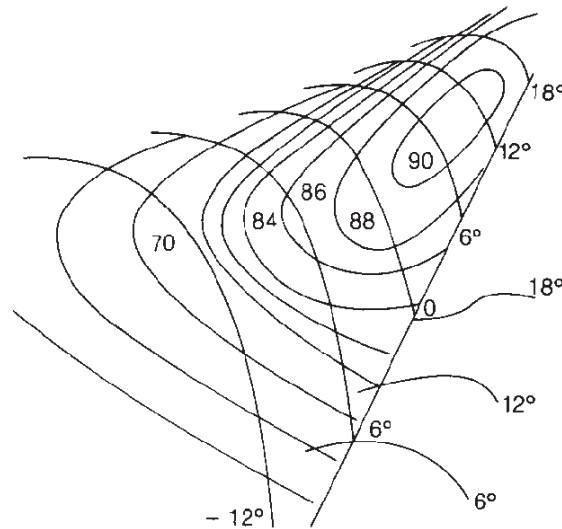

## The axial fan with the low noise

A high efficiency alone is not sufficient to obtain a max. reduction in the total noise level. By reducing the amount of impeller wings, f. inst. from 12 to 8 or from 8 to 6, it is without doubt possible to find a reduction in the sound pressure.

The frequency based evaluation of the total sound pressure level at a given distance in dB(A) based on the customer's required working point, can be calculated with a computer based on empiric measurements.

## The axial fan having max. stability

Through several decades of experience in production of fans and other process equipment for the industry, we are aware of our responsibility with regard to safe operation for the equipment. The best material selection together with good craftsmanship is of great importance, whether the fan shall be installed in conjunction with a paper machine, for ventilation of large production areas or utilized in the offshore industry under severe conditions.

Dependent on the design, the motor can be flanged directly to the central tube and the fan impeller mounted directly on to the motor shaft. Using belt drive where the bearings and the shaft are mounted into the central tube, the central tube will be fixed in the center of the fan housing through heavy gauge guide vanes.

For obtaining a max. stability, heavy gauge materials are utilized. Fan requiring motor powers of 75 kW or above, has as a standard 5 mm sheet metal thickness. Flanges on fan sizes up to 1200 are at least 8 mm. For fan sizes 1250 up to 2000, a flange thickness of 12 mm will be used. The flanges are fully welded to the fan housing.

The fan impeller wings and hub are made in cast silumin G-A1 Si 10 Mg. Profile thickness in the impeller wing is for example for a fan having a hub diameter of 630 mm up to 37 mm. This indicates the great stability of the fan impeller. An impeller for fan 1250.500.8 has a weight 59 kgs.

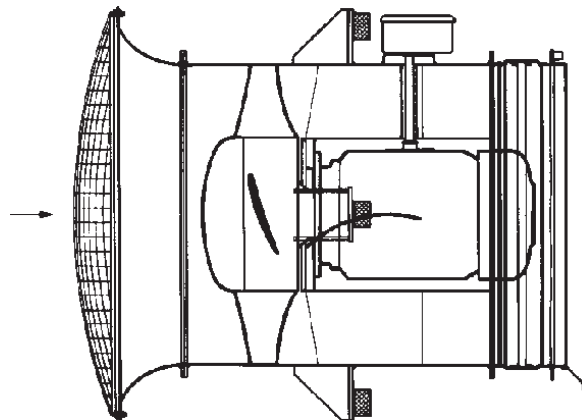

## The axial fan having a max. flexibility

The axial fan type M 80 will as a standard be delivered in St. 37.2, precoated and painted with a top coat. If required the fan can be supplied epoxy painted or hot dipped galvanized.

In cases where there are special requirements with regard to corrosion resistants, the fan can be made in special corrosion resistant materials as aluminium or various grades of stainless steel. Does the fan operate in areas where condensation occurs, the impeller hub will be drained.

Running at high temperatures and direct drive, the motor can be supplied with insulation class F. Using belt drive and at high temperature the bearings can be greased with high temperature grease.

The fan can be delivered with brackets for vertical- or horizontal erection.

## Accessories

The following accessories in various materials can be supplied:

- inlet cone with protection grill
- inlet- and outlet compensators
- diffusor
- mounting frames
- epoxy painting
- galvanizing